

Disposable Filter Applications

Cost effective way to collect, dewater, transport and dump all kinds of sludges, slurries, and wet solids.

GeoCat™ Model RO

The GeoCat dewatering box comes with disposable filter media. The GeoCat is designed to be used with sticky, or slimy, slightly oily, non-uniform, non-specific, colloidal, or simply hard to dewater sludge where flocculation is not an option.

The GeoCat is also useful for dewatering operations in which the residual sludge cake would present a clean-up issue, as the disposable filter is discarded with the filter cake.

Log on to ParkProcess.com for more information.



Roll-Off

► Features

- Heavy duty carbon steel construction (optional stainless steel) 1/4" floor and 3/16" side walls with round bottom design, 6" x 2" x 1/4" bottom rails with steel wheels
- Gasketed, hinged water tight rear door
- Designed to be handled by a standard hook and cable type roll-off truck (hook lift type mechanisms optional)
- Typical (4) 3" drain ports located at the bottom on each side at opposing ends
- Steel expanded metal and perforated plate basket supports the filter media (optional materials for support panels)
- Disposable filter media is available in 3, 4, 6, and 10 ounce fabric as well as a woven 40 mesh polypropylene filter and is made into an envelope shape, held in place by bag hooks around the top perimeter of the container
- A double wall filter element that splits the container into two compartments is an available option (more than one double filter is also an option)
- Micron size filters from 3,360 microns to 170 microns (6 mesh to 80 mesh)
- Container sizes available: 15, 20, 30, and 40 cubic yards



► Applications

- Water Treatment Plants
- Gas Scrubber Ash
- Arsenic Sludge
- Alum Sludge

Dewatering Containers

- Self Dumping Hoppers
- Front Loaders
- Roll-Offs
- Permanently Mounted Tipping Stand
- Trailer Mounted
- Rotator Boxes
- Crane Dumping
- Filter Media

Filtration Equipment

- Cartridge Filter Vessels
- Cartridge Filters
- Bag Filter Vessels
- Bag Filters
- Filter Presses (Standard/Oilfield)
- Filter Press Cloths
- Sand Filters
- Back Wash Filters
- Carbon Filters
- Filter Media (Permanent /Disposable)

Separation Equipment

- Oil/Water Separators
- Hydrocyclones
- Vibratory Screening Units
- Inclined Plate Clarifier
- Grit Classifiers
- Strainers
- Oil Skimmers
- Mud Cleaners
- Centrifuges

Mixing/Blending

- Static Mixers
- Eductors
- Batch Mixing Systems
- Tank Mixers
- Agitators
- Blend Plants
- Blending Units
- Mud Shearing

Chemical Treatment

- Polymer Mixing & Injection
- Static Mixers
- PH Control Systems
- Slurry Tanks

Pumping

- Centrifugal Pumps
- Progressive Cavity Pumps
- Diaphragm Pumps
- Trash Pumps

Conveyance

- Screw Conveyors
- Drag Conveyors

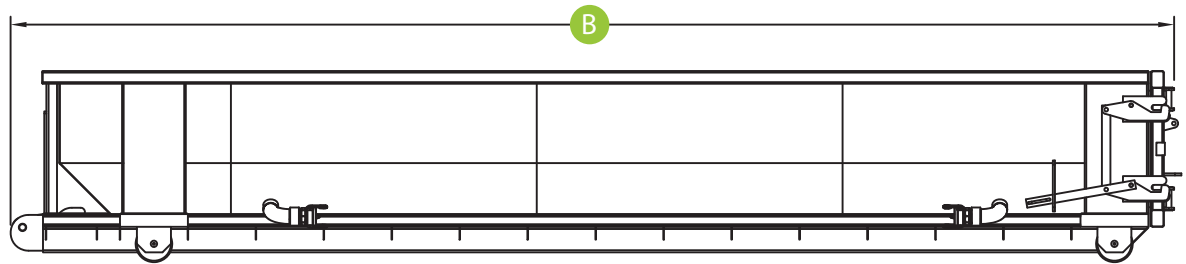
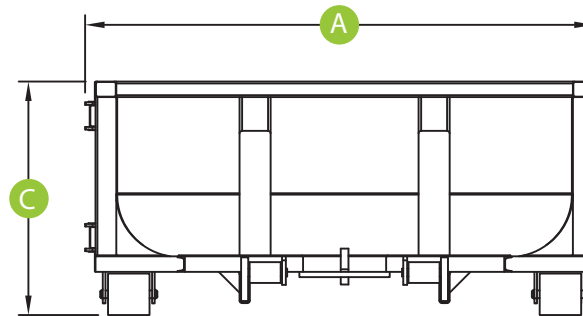

Model	Size	A	B	C
GERO15	15 yd	102	270.625	45
GERO20	20 yd	102	270.625	55
GERO25	25 yd	102	270.625	65
GERO30	30 yd	102	270.625	75
GERO40	40 yd	102	270.625	96

*Specifications subject to change without notice.
 Measurements in inches and weights in pounds.
 *NOTE: LARGER SIZES AVAILABLE UPON REQUEST

Other available models:



Self Dumping Hopper (DH)



Front Loader (FL)